

High pressure reverse control all-in-one machine

HF4830S60-H/HF4850S80-H

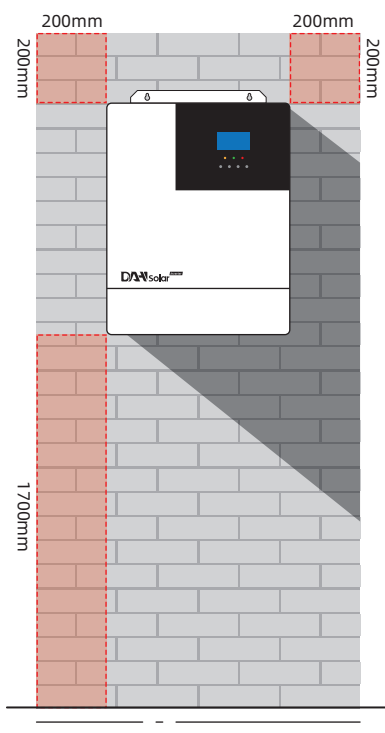

Product overview

HF48-H series is a new all-in-one hybrid solar charge inverter, which integrates solar energy storage & means charging energy storage and AC sine wave output. Thanks to DSP control and advanced control algorithm, it has high response speed, high reliability and high industrial standard.

Performance characteristics

- Adopt full digital voltage and current double closed-loop control and advanced SPWM technology to output pure sine wave.
- Two output modes, i.e. mains bypass and inverter output can achieve uninterrupted power supply function.
- Available in 4 charging modes: Only Solar, Mains Priority, Solar Priority and Mains & Solar hybrid charging.
- Advanced MPPT technology, with efficiency up to 99.9%.
- Wide MPPT voltage range, 120-450Vdc.
- There is no commercial power or battery, and the solar energy has independent loading function.
- With function of activating lithium battery with solar energy and AC mains power, it supports connection of lead-acid battery and lithium battery.
- LCD screen design and 3 LED indicator lights dynamically display system data and operation states.
- ON/OFF rocker switch can control AC output.
- With power saving mode function, it can reduce no-load loss.
- Intelligent adjustable speed fan is adopted for efficient heat dissipation and extended system life.
- Possessing multiple protection functions and 360° comprehensive protection.
- Possessing complete short circuit protection, overvoltage and undervoltage protection, overload protection, back filling protection, etc.

Product connection diagram

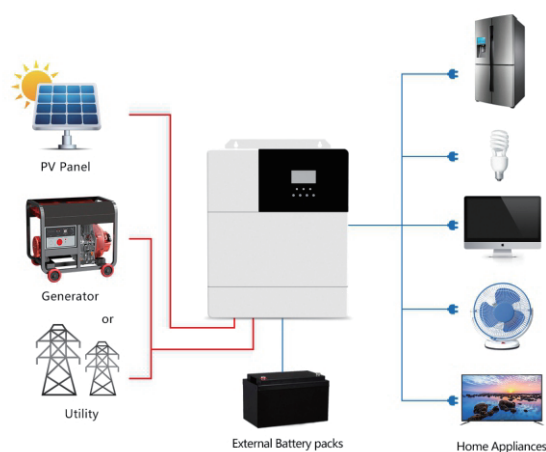

Appearance

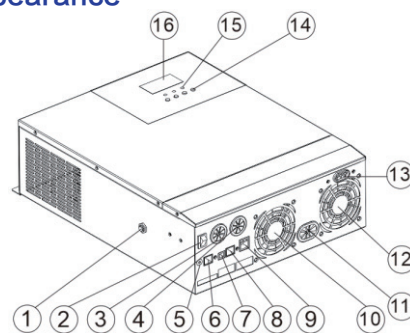

①	Overload protector	⑨	Dry contact port
②	ON/OFF rocker switch	⑩	Cooling fan
③	AC input port	⑪	Battery port
④	AC output port	⑫	Cooling fan
⑤	Grounding screw hold	⑬	PV port
⑥	RS485-2 communication port	⑭	Touch the key lightly
⑦	USB communication port	⑮	Indicator light
⑧	RS485-1 communication port	⑯	LCD screen

Technical parameters >>>

Model	HF4830S60-H	HF4850S80-H
AC mode		
Rated input voltage	220/230Vac	
Input voltage range	(170Vac~280Vac) ±2% ; (90Vac-280Vac) ±2%	
Frequency	50Hz/ 60Hz (auto-sensing)	
Frequency Range	47±0.3Hz ~ 55±0.3Hz (50Hz)/57±0.3Hz ~ 65±0.3Hz (60Hz);	
Overload/short circuit protection	Breaker	
Efficiency	>95%	
Conversion time (bypass and inverter)	10ms (Typical value)	
AC reverse protection	yes	
Maximum bypass overload current	30A	40A
Inverting mode		
Output voltage waveform	Pure sine wave	
Rated output power(VA)	3000	5000
Rated output power(W)	3000	5000
Power factor	1	
Rated output voltage (Vac)	230Vac	
Output voltage error	±5%	
Output frequency range (Hz)	50Hz ± 0.3Hz/60Hz ± 0.3Hz	
Efficiency	>90%	
Overload protection	(102% <load <125%) ±10%: reporting error and turn off the output after 5 minutes; (125% <load <150%) ±10%: reporting error and turn off the output after 10 seconds; Load >150% ±10%: reporting error and turn off the output after 5 seconds;	
Peak power	6000VA	10000VA
Loaded motor capacity	2HP	4HP
Output short-circuit protection	Breaker	
Specification of bypass breaker	30A	40A
Rated battery input voltage	48V (minimum start voltage 44V)	
Battery voltage range	40.0Vdc~60Vdc ± 0.6Vdc (undervoltage alarm/turnoff voltage/overvoltage alarm/overvoltage restoration...settable LCD screen)	
Power saving mode	Load ≤25W	
AC charge		
Battery type	Lead acid or lithium battery	
Maximum charge current	60A	60A
Charge current error	± 5Adc	
Charge voltage range	40~60Vdc	
Short-circuit protection	Circuit breaker and blown fuse	
Breaker specification	30A	40A
Overcharge protection	Alarm and turn off charging after 1 minute	
Solar charge		
Maximum PV opencircuit voltage	500Vdc	
PV operation voltage range	120-500Vdc	
MPPT voltage range	120-450Vdc	
Battery voltage range	40-60Vdc	
Maximum output power	3000W	5000W
Charge current range of solar energy (settable)	0-60A	0-80A
Charge short-circuit protection	Blown fuse	
Wiring protection	Reverse polarity protection	
Authentication specification		
Specification authentication	CE(IEC/EN62109-1,-2), ROHS2.0	
EMC authentication grade	EN61000	
Operation temperature range	-15°C to 55°C	
Storage temperature range	-25°C ~ 60°C	
Humidity range	5% to 95% (Conformal coating protection)	
Noise	≤60dB	
Thermal dissipation	Forced air cooling, variable speed of fan	
Communication interface	USB/RS485(Bluetooth/WiFi/GPRS)/Dry node control	
Dimension (L*W*D)	426mm*322mm*126mm	
Weight (kg)	11	